

130508-( )-( )

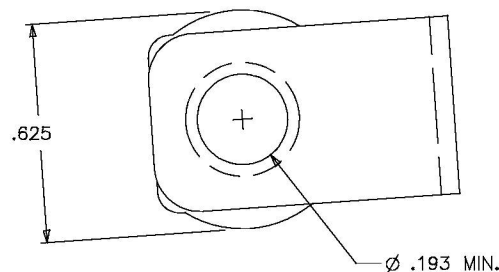
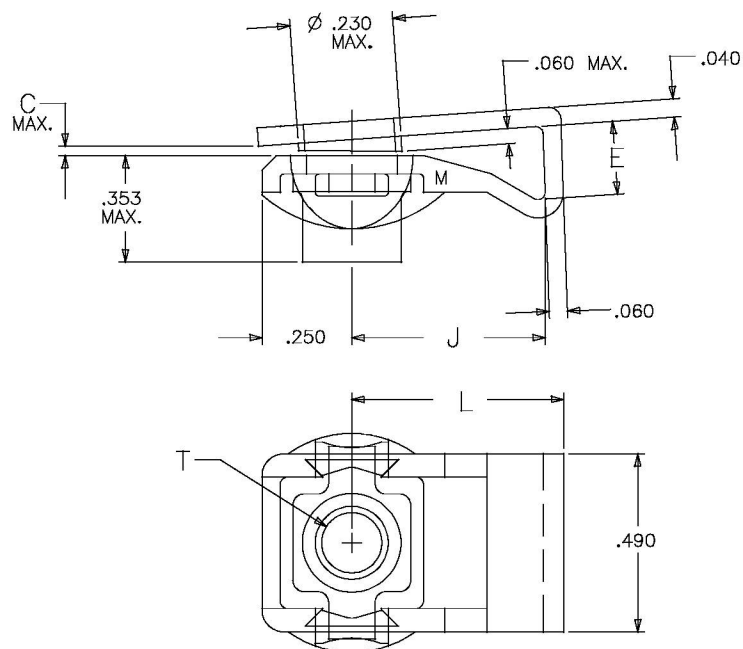

TABLE I

FIRST DASH NUMBER	T THREAD PER MILS-S-8879
04	.1120-40UNJC-3B
06	.1380-32UNJC-3B
08	.1640-32UNJC-3B
3	.1900-32UNJC-3B

TABLE II

SECOND DASH NUMBER	PANEL GRIP RANGE		E	L	J	C MAX.
	MINIMUM	MAXIMUM				
-1	.020	.160	.175	.775	.735	.050
-2	.140	.300	.315			.170



NOTES:

- MATERIAL:
  - 1.1 CLIP: TORLON 4203L PER ASTM D 5204, TYPE I
  - 1.2 NUT: A286 CRES PER AMS5731 OR AMS5734
- FINISH:
  - 2.1 CLIP: NONE
  - 2.2 NUT: CADMIUM PLATED PER AMS-QQ-P-416, TYPE II, CLASS 2 AND DRY FILM LUBRICATED PER AS5272 TYPE I.
- HARDWARE PROCURED IN ACCORDANCE WITH BOEING PART STANDARD BACN11AL.
- PART NUMBER EXAMPLE: 1 3 0 5 0 8 - ( ) - ( )
  - EDGE DISTANCE AND PANEL GRIP -1 OR -2 (SEE TABLE)
  - THREAD SIZE 0440, 0632, 0832 AND 1032 (SEE TABLE)
  - BASIC PART NUMBER

PATENT APPLIED FOR- FILING DATE 04-18-01, SERIAL NO. 09/837,391

B	ECN # 7784	06-21-02
A	ECN # 7743	04-30-02
ISSUE	DESCRIPTION	DATE
REVISION		0113-006

REPRODUCTION OF THIS DRAWING OR MANUFACTURE OF THE PROPRIETARY PARTS SHOWN HERE WITHOUT WRITTEN PERMISSION OF THE MONADNOCK COMPANY IS PROHIBITED.

NEXT ASSEMBLY END ITEM	UNLESS OTHERWISE SPECIFIED DIMENSIONS ARE IN INCHES. TOLERANCES DECIMALS FRACTION ANGLES ±.010	DRAWN BY: R.A.D. 08-14-01	DATE: 08-14-01	THE MONADNOCK COMPANY CITY OF INDUSTRY, CALIFORNIA TITLE: CLIP NUT SELF LOCKING NUT, COMPOSITE CODE IDENT. NO. 60119 SIZE B DRAWING NUMBER: 130508-( )-( ) SCALE: NONE SALES SHEET 1 OF 1
	MATERIAL: NOTED	CHECKED BY: R.DUENAS 08-14-01	DATE: 08-14-01	
	HEAT TREAT:	APPROVED BY: T.S.C. 08-15-01	DATE: 08-15-01	
	FINAL PROTECTIVE FINISH: NOTED	APPROVED BY: J.V.F. 08-15-01	DATE: 08-15-01	
		MFG. ACCEPT: D.PAUL 08-16-01	DATE: 08-16-01	